

**Caution – Risk of Electric Shock!** Vorsicht - GEFAHR EINES STROMSCHLAGS! ATENCIÓN - RIESGO DE DESCARGA ELÉCTRICA! Attenzione - RISCHIO DI SCOSSA ELETTRICA! ATTENTION - RISQUE DE CHOC ÉLECTRIQUE! Voorzichtig - GEVAAR VOOR EEN ELEKTRISCHE SCHOK! POZORI - Riziko úrazu elektrickým proudem.

The light source contained in this luminaire shall only be replaced by the manufacturer or his service agent or a similar qualified person. Das in dieser Leuchte enthaltene Leuchtmittel darf nur durch den Hersteller, seinen Kundendienst oder entsprechend qualifiziertes Fachpersonal ausgetauscht werden. La fuente de iluminación de esta luminaria solo debe ser sustituida por el fabricante o su agente de servicio, o en su caso, por personal cualificado. La sorgente luminosa contenuta in questo apparecchio deve essere sostituita esclusivamente dal produttore, dal suo rappresentante o da una persona similmente qualificata. La source lumineuse contenue dans ce luminaire ne doit être remplacée que par le fabricant ou son agent de maintenance ou une personne de qualification équivalente. De lichtbron in deze lamp mag alleen worden vervangen door de fabrikant, zijn serviceagent of een vergelijkbaar gekwalificeerd persoon. Zdroj světla v tomto svítidle smí být vyměněn pouze elektrikářem, nebo servisním agentem výrobce.



If the external flexible cable or cord of this luminaire is damaged, it shall be exclusively replaced by the manufacturer or his service agent or a similar qualified person in order to avoid a hazard. Falls das externe flexible Kabel dieser Leuchte beschädigt ist, muss es zur Vermeidung von Gefahren vom Hersteller oder dessen Servicemitarbeitern oder einer ähnlich qualifizierten Person ausgetauscht werden. Para evitar riesgos, si el cable flexible externo de esta luminaria está dañado, debe reemplazarlo el fabricante o su representante técnico, u otra persona de cualificación similar. Se il cavo esterno flessibile è danneggiato, farlo sostituire dal produttore, dal servizio assistenza o da personale qualificato per evitare qualsiasi pericolo. si le câble ou le cordon extérieur souple de ce luminaire est endommagé, il doit être remplacé exclusivement par le fabricant ou son agent de maintenance ou toute personne de qualification équivalente, cela afin d'éviter tout risque. Als de externe flexibele kabel of draad van deze lamp is beschadigd, dan moet deze worden vervangen door de fabrikant of service-agent of een persoon met gelijkwaardige kwalificaties om kans op letsel te voorkomen. Je-li externí přívodní kabel poškozen, musí být vyměněn pouze elektrikářem, nebo servisním agentem výrobce.

	<b>P</b>	<b>I</b>			<b>Ta</b>
			L (mm)	H (mm)	
FHB71000v0-dc/ds+060D	150/125/100/90/70W	720/600/480/430/330mA	300	135	60
FHB71000v0-dc/ds+110D	150/125/100/90/70W	720/600/480/430/330mA	300	145	60
FHB71000v1-dc/ds+110D	165/125/115/90/80W	800/600/550/430/380mA	300	145	50



## Accessories (please order separately.)

### 0-10V Function

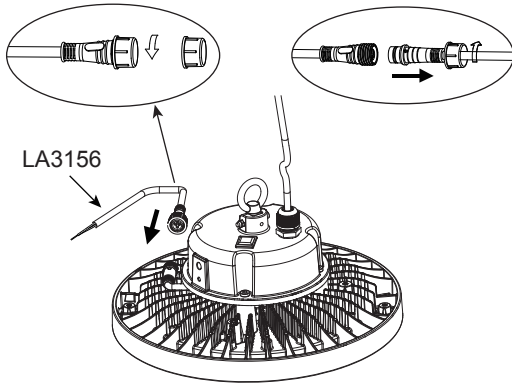

LA3156

### Reflector

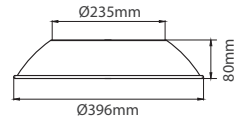

LA3133

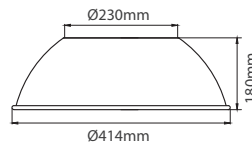

LA3134

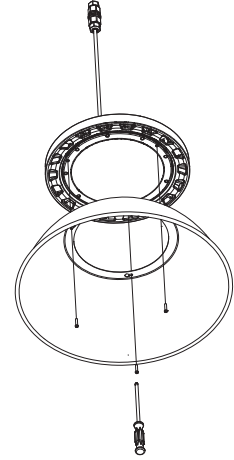

### Sensor Kit

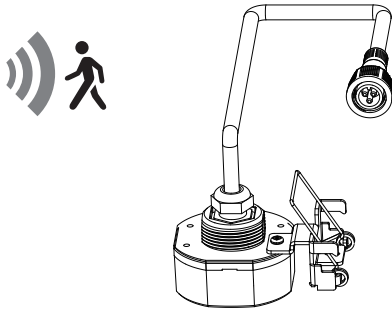

LA11189

### DALI Kit

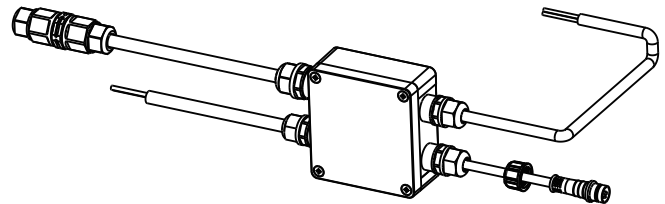

LA11177